



SPARTAN CHASSIS, INC.

TSB06-110-001A

November, 2006

Page 1 of 3

TECHNICAL SERVICE BULLETIN

SUBJECT: Cab Doors - Front

APPLIES TO: Spartan Fire Truck Cabs Manufactured before October 31, 2006

CONDITION: Gap between window and door frame.

Bulletin #TSB06-110-00A supersedes bulletin #TSB06-110-001. A part number was changed. Any vehicle repaired under the initial bulletin procedure does not require additional repair.

PLEASE READ THE ENTIRE BULLETIN BEFORE PROCEEDING WITH ANY WORK. CONTACT SPARTAN CHASSIS IF THERE ARE ANY CONCERNS WITH THE PROCEDURES CONTAINED IN THIS DOCUMENT

PART / SERVICE INFORMATION:

Labor Time: 1.0 hr.

<u>QTY.</u>	<u>Part Number</u>	<u>Description</u>
1	S-1783-001A	Kit-Gusset Front Door Frames

Kit # S-1783-001A Contains:

<u>QTY.</u>	<u>Part Number</u>	<u>Description</u>
2	S-1781-001	Gusset- FR. Door Frames
2	0832050FCTC23Z	Screw- #08-32X0.50 LG. Flat CSunk Thread Cutting Zinc
4.58	0601-EE3-001	55"Seal-Window Wipe
1	TSB06-110-001A	Document Instructions

STEP-BY-STEP INSTRUCTIONS:

1. Observe all industry safety standards and secure vehicle to allow for the rework of the cab door frame gusset.

Technical Service Bulletins are intended for use by Professional Technicians only. They are written to guide Professional Technicians in performing service to vehicles of product specific nature in conjunction with industry standards. Professional Technicians are appropriately trained on industry standards and have the tools and equipment to perform procedures safely and properly.



SPARTAN CHASSIS, INC.

TSB06-110-001A

November, 2006

Page 2 of 3

TECHNICAL SERVICE BULLETIN

2. Refer to FIG.2-1. Disassemble black window trim ring from outside of one front door by removing (8) screws. Retain window trim and screws for reuse. Remove rubber window wipe strip and discard.
3. Refer to FIG. 3-1. Remove film from double sided tape on gusset and firmly place where shown. Tape side down to upper door support, keeping adjacent against inside of door frame.

Note: Do not allow gusset to protrude into window track area.

4. Using the gusset as a guide, drill (1) .144 diameter hole into side door frame for self threading screw.

Note: Cut window wipe strip to 27.5”

5. Refer to FIG. 3-2. Firmly attach gusset using screw from kit.
6. Reattach new window wipe strip along door upper support riding up onto newly attached gusset.

Caution: Do not allow window wipe strip to extend into window track area.

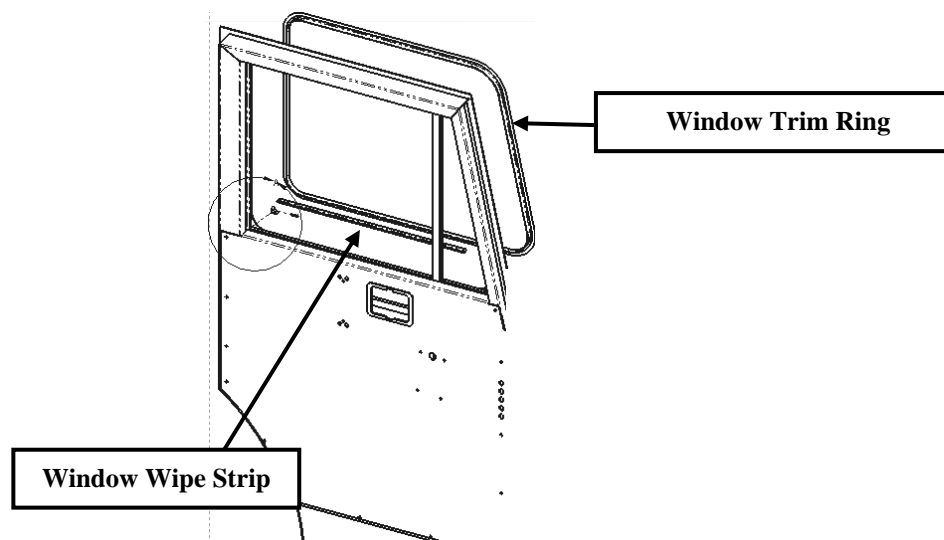

Door Frame

FIG. 2-1

Technical Service Bulletins are intended for use by Professional Technicians only. They are written to guide Professional Technicians in performing service to vehicles of product specific nature in conjunction with industry standards. Professional Technicians are appropriately trained on industry standards and have the tools and equipment to perform procedures safely and properly.



SPARTAN CHASSIS, INC.

TSB06-110-001A

November, 2006

Page 3 of 3

TECHNICAL SERVICE BULLETIN

7. Replace black trim ring using screws retained from step 2.
8. Repeat steps 2 thru 6 for the other front door.

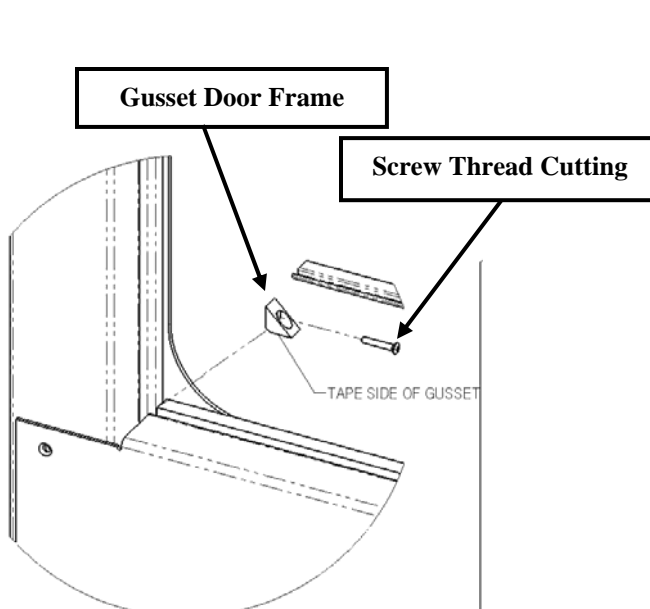

Door Frame With Gusset

FIG. 3-1

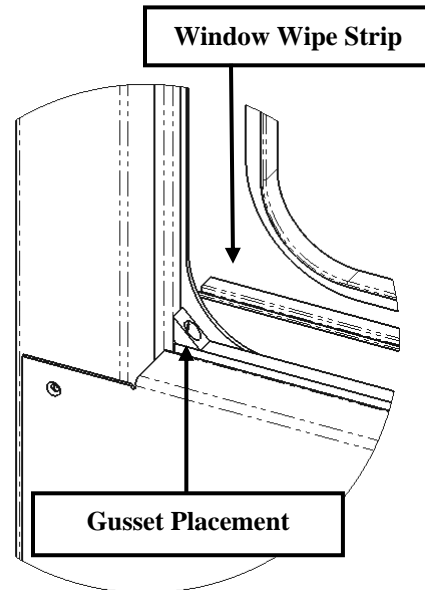

Door Frame Shown With Gusset Placement

FIG. 3-2

Technical Service Bulletins are intended for use by Professional Technicians only. They are written to guide Professional Technicians in performing service to vehicles of product specific nature in conjunction with industry standards. Professional Technicians are appropriately trained on industry standards and have the tools and equipment to perform procedures safely and properly.