



SPARTAN CHASSIS, INC.

TSB07-210-001

March, 2007

Page 1 of 2

TECHNICAL SERVICE BULLETIN

- SUBJECT:** Frame - Cab Mounting
- APPLIES TO:** Certain Spartan Firetrucks with a VDM (Vehicle Date of Manufacture) of May 23, 2001 through March 15, 2007.
- CONDITION:** Cab mount to frame fasteners are failing

PLEASE READ THE ENTIRE BULLETIN BEFORE PROCEEDING WITH ANY WORK. CONTACT SPARTAN CHASSIS IF THERE ARE ANY CONCERNS WITH THE PROCEDURES CONTAINED IN THIS DOCUMENT

PART / SERVICE INFORMATION:

Labor Time: 1.5 Hrs.

<u>QTY.</u>	<u>Part Number</u>	<u>Description</u>
1	S-1828-001	Kit-Cab Mount Isolated Latch

Kit # S-1828-001 Contains:

<u>QTY.</u>	<u>Part Number</u>	<u>Description</u>
8	09120200FH8Y	Bolt 9/16"-12 x 2.00" Flg. Gr.8
8	0912FLN8Y	Nut 9/16"-12 Toplock Flg.
1	TSB07-210-001	Document Instructions

Technical Service Bulletins are intended for use by Professional Technicians only. They are written to guide Professional Technicians in performing service to vehicles of product specific nature in conjunction with industry standards. Professional Technicians are appropriately trained on industry standards and have the tools and equipment to perform procedures safely and properly.



SPARTAN CHASSIS, INC.

TSB07-210-001

March, 2007

Page 2 of 2

TECHNICAL SERVICE BULLETIN

STEP-BY-STEP INSTRUCTIONS:

1. Observe all industry safety standards and secure vehicle for removal and installation of cab mount isolated latch.
2. Tilt cab and insure safety bracket is engaged.
3. Refer to FIG. 2-1. Locate and remove cab mount isolated latch assembly, save assembly and spacer for reuse. Discard fasteners.
4. Enlarge the four (4) mounting holes to 19/32" or .594 on the assembly and spacer if present.

NOTE: Some chassis may not have the spacers.

5. Enlarge the four (4) holes to 19/32" or .594 on the frame rail.
6. Reinstall the assembly and spacer, insuring the spacer is between the assembly and frame rail, using the fasteners supplied in the kit. Torque to 95 ft. lbs.

NOTE: Fasteners must be installed from the inside of frame-rail to the outside of frame-rail.

7. Repeat step 3 through 6 for the opposite side.

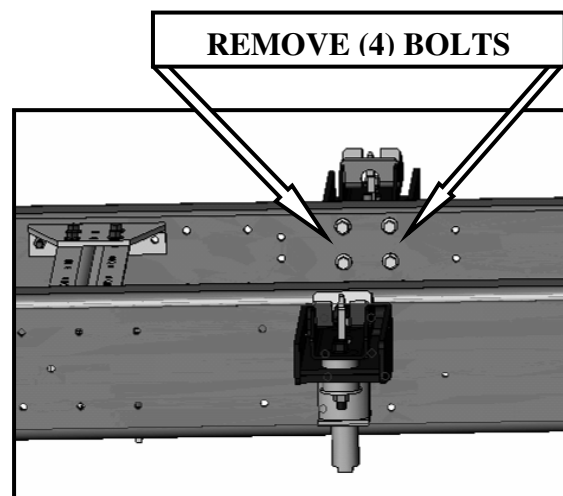
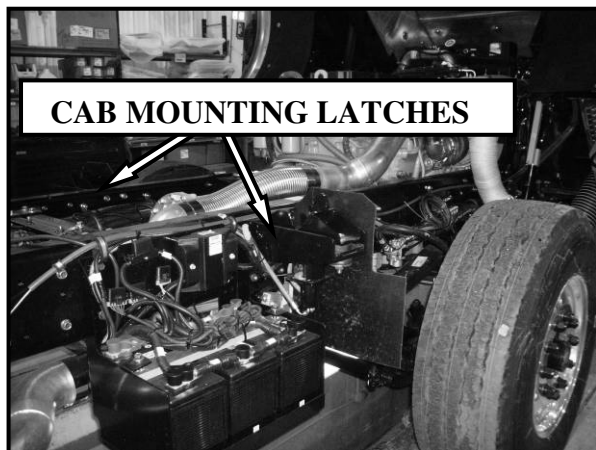

CAB MOUNT ISOLATED LATCH

FIG. 2-1

Technical Service Bulletins are intended for use by Professional Technicians only. They are written to guide Professional Technicians in performing service to vehicles of product specific nature in conjunction with industry standards. Professional Technicians are appropriately trained on industry standards and have the tools and equipment to perform procedures safely and properly.